

MANUAL PASTA MAKER

1507252/ 9007252 - Instruction Manual

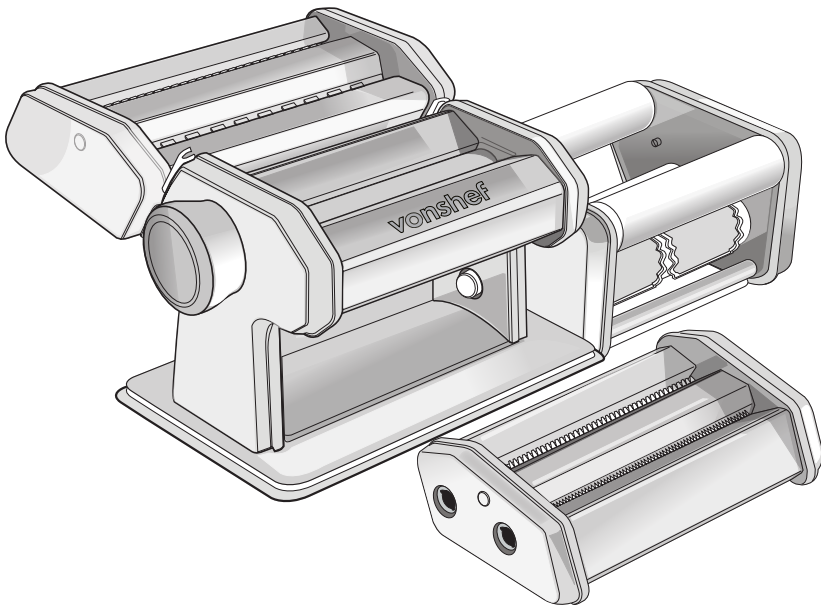

CONTENTS

Safety Instructions	1
Specification	2
Before First Use, Operation	3
Attachments	4
Ravioli Fillings & Sauces	5
Cleaning & Maintenance, Warranty	6

SAFETY INSTRUCTIONS



PLEASE READ THESE INSTRUCTIONS CAREFULLY AND KEEP FOR FUTURE REFERENCE.

INTENDED USE.

Only operate the VonShef Manual Pasta Maker for its intended purpose and within the parameters specified in this manual.

This Pasta Maker is intended for domestic use only. Do not use for commercial purposes.

This appliance is not intended for use by persons with reduced physical, sensory or mental capabilities, or lack of experience and knowledge, unless supervised or given appropriate instruction concerning the product's use by a person responsible for their safety.

This appliance is not intended for use by children.

GENERAL PRECAUTIONS

This appliance is not a toy. Children should be supervised to ensure they do not play with the Pasta Maker.

If the Pasta Maker is not functioning properly, has been dropped, damaged, left outdoors, or immersed in liquid, do not use, contact DOMU Brands Customer Services.

Do not use the Pasta Maker if any parts appear to be faulty, missing or damaged.

Ensure all parts are securely attached before use.

CAUTION: Your VonShef Pasta Maker is not suitable for use in a dishwasher.

RISK OF PERSONAL INJURY

Keep hair, loose clothing, fingers and all parts of body away from openings and moving parts.

Do not insert any knives or cleaning cloths between the rollers.

Do not insert any foreign bodies or body parts into the Pasta Maker.

Do not drop the Pasta Maker or allow it to be knocked violently.

Always ensure the Handle is securely fitted before turning. Turn in smooth, circular motions. Incomplete or jerky motions can damage the device.

Do not immerse the appliance in water or any other liquids to clean.

Do not lubricate any parts or carry out any maintenance or repair work other than that shown in this manual, or as advised by the DOMU Brands Customer Care Helpline.

Do not combine parts with other products or other manufacturer's products. In order to prevent damage to the appliance, use DOMU Brands recommended accessories only.

PRODUCT SPECIFICATION

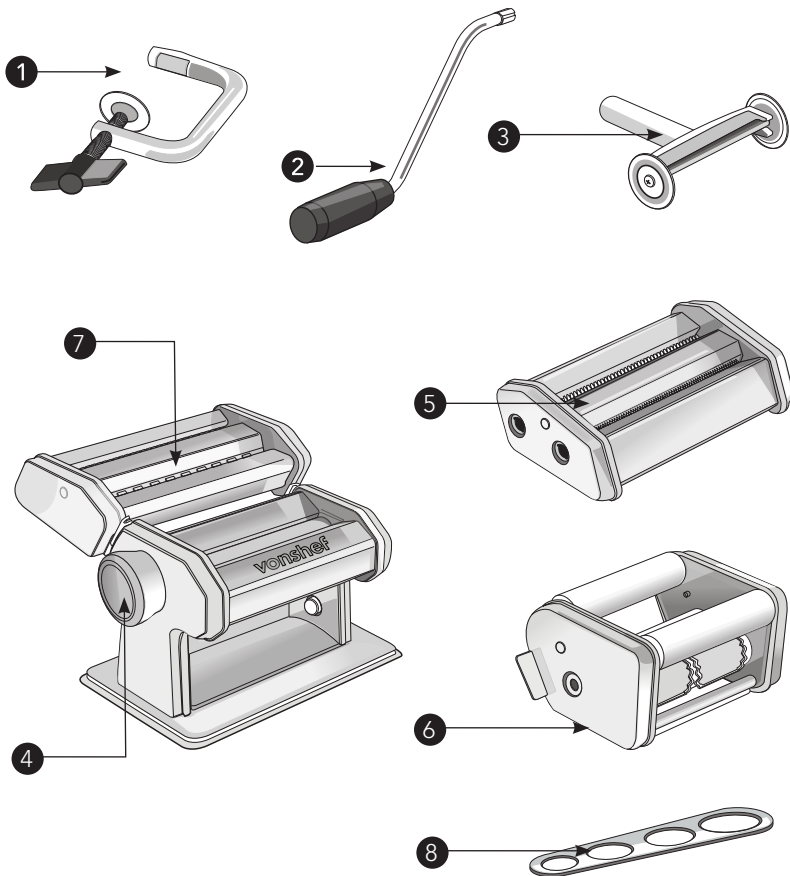

1. CLAMP.

2. HANDLE.

3. DOUGH CUTTER.

4. THICKNESS DIAL.

5. SPAGHETTI ATTACHMENT.

6. RAVIOLI ATTACHMENT.

7. TAGLIATELLE ATTACHMENT.

8. PASTA MEASUREMENT TOOL.

BEFORE FIRST USE

Before using this appliance for the first time, please ensure you complete the following steps:

- Carefully unpack the Pasta Maker and remove all packaging materials including any stickers or labels.
- Place the Pasta Maker on a flat, dry surface. Position near a suitable edge and attach the **CLAMP** to the surface and through the hole on the side near the base. Tighten to secure.
CAUTION: Do not over-tighten the **CLAMP** as this may damage your surface and the Pasta Maker.
- Insert the **HANDLE** into the Pasta Maker and turn gently in smooth circular motions. Lightly flour the rollers with 00 grade flour to prevent the dough from sticking.
- To clean, prepare a basic dough mix and pass a small amount through each roller a few times to remove any residues. Dispose of the dough after this process.



WARNING! Never immerse your VonShef Pasta Maker in water or any other liquid for any reason. Do not wipe down with wet cloths or sponges as these can damage the rollers. Refer to the '**Cleaning & Maintenance**' section for guidance on how to clean your Pasta Maker.

ASSEMBLY

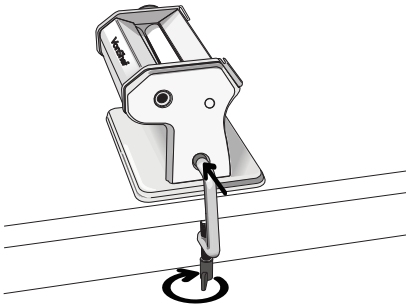

- Clamp the Pasta Maker unit to a flat and stable work surface. Tighten the clamp securely to the surface. Ensure you do not over-tighten.

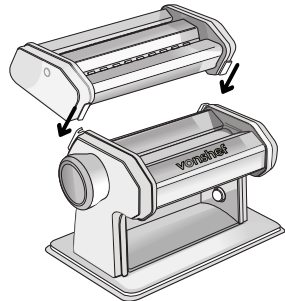

- Carefully align your chosen cutting attachment to the tracks on the top of the Pasta Maker. Slot the runners along the cutting attachment into the tracks and gently slide into position until secure.

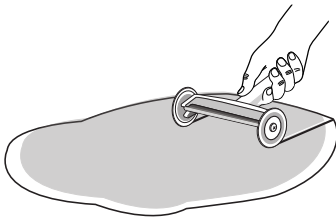

- Prepare your dough mixture and cut to size using the **DOUGH CUTTER**. This will ensure the dough is a suitable size to feed through the Pasta Maker.

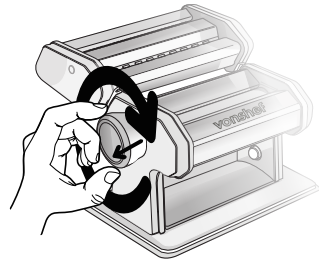

- To adjust to rollers to the desired thickness, simply pull the **THICKNESS DIAL** slightly and turn to the required labelled number.

ATTACHMENTS

SPAGHETTI & TAGLIATELLE

- Before attaching the **SPAGHETTI, TAGLIATELLE ATTACHMENTS**, fix the **HANDLE** to the side of the Pasta Maker. Lightly dust the rollers before feeding the dough through and slowly turning the **HANDLE**. Depending on your desired thickness you may wish to repeat this step 4-5 times, adjusting the **THICKNESS DIAL** after each turn.
NOTE: You may need to add flour to the rollers between stages to ensure dough does not stick.
- Slide the **SPAGHETTI** or **TAGLIATELLE** attachment onto the rails at the rear of the Pasta Maker ensuring it is securely in position. Remove the **HANDLE** from the side of the Pasta Maker and fix it to the attachment.
CAUTION: Exercise care when using the cutting attachments as these contain sharp blades and moving parts which can trap hair, skin or loose clothing and cause injury.
- Carefully feed the rolled dough into the attachment and slowly turn the **HANDLE** to dispense.
- Once cut, fresh pasta should be dusted with semolina (preferably) or flour to keep it from sticking if you are not planning to cook it straight away. You can lay it on a semolina- or flour-dusted baking sheet or linen kitchen towel until ready to boil. Alternatively, drape it over a suspended rolling pin or pasta drying rack until ready to use.

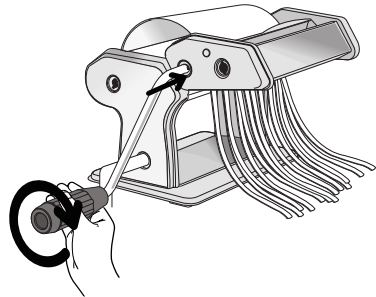
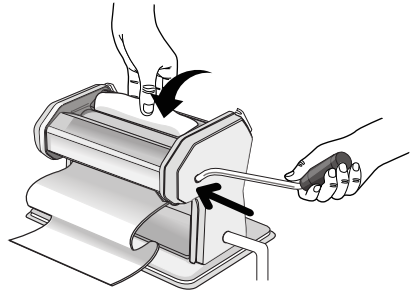

RAVIOLI

- Adjust the **THICKNESS DIAL** to 8 or 9 and feed your prepared dough (dusted with flour) through the appliance several times.
- Slide the **RAVIOLI ATTACHMENT** onto the rails and ensure it is securely in position. Insert the **HANDLE** into the slot on the side of the **RAVIOLI ATTACHMENT**.
- You can feed two dough sheets through the appliance by placing them over the 2 rollers. Slowly turn the **HANDLE** to begin cutting.
- Once the ravioli sheets have emerged from below, lay them down on a flour-dusted surface. Remove any excess dough and roll up into a ball. This can then be wrapped in cling film and kept fresh in the refrigerator for later use.
- Using a teaspoon, add your chosen filling to the centre of each cut out. Be careful not to overfill the centres. Lightly brush the edges with egg yolk or water before placing the rest of the cut outs on top. Firmly press the edges down to seal.
- Half fill a large pan with water, add 1 teaspoon of salt and bring to the boil. Carefully add the ravioli pieces individually to the water. Cook for 5-6 minutes (you could make some extra ravioli to test the cooking time).
- Remove the ravioli from the pan using a slotted spoon and serve whilst still warm.

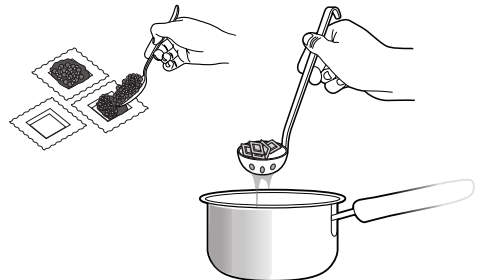
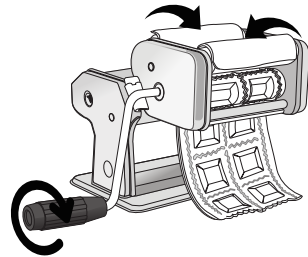

RAVIOLI FILLINGS & SAUCES

Pork & Parmesan Ravioli with Tomato Sauce

FILLING -

- 3 tbsp olive oil
- 500g pork mince
- 3 garlic cloves, finely chopped
- 1 onion, finely chopped
- 1 celery stalk, trimmed, finely chopped
- 2 free-range eggs
- 3 tbsp chopped fresh parsley
- 3 tbsp grated parmesan, plus extra to garnish
- 3 tbsp tomato sauce (see below)

SAUCE -

- 3 tbsp olive oil
- 3 garlic cloves, finely chopped
- 1 celery stalk, trimmed, finely chopped
- 1 onion, finely chopped
- 700g passata
- 2 tbsp chopped fresh basil
- 2 tsp dried oregano
- 1 tsp caster sugar
- pinch salt, to taste

METHOD -

1. To make the sauce, heat the oil in a separate frying pan over a medium heat. Add the garlic, celery and onion and fry for 6-8 minutes, or until just coloured. Add the passata and 300ml water, stir the mixture well and bring to the boil.
2. Reduce the heat until the mixture is simmering and simmer gently for 30 minutes, then stir in the basil, oregano, sugar and salt. Keep warm
3. For the filling, heat the oil in a saucepan over a medium heat. Add the pork mince, garlic, onion and celery and fry gently for 12-15 minutes, or until the pork has browned and the vegetables have softened. Remove from the heat and set aside to cool.
4. When the filling mixture has cooled, blend it to a rough paste in a food processor, then transfer to a bowl. Beat in the eggs, parsley, parmesan and 3 tablespoons of the tomato sauce until well combined. Spoon a little of the filling mixture into the centre of each ravioli (use the wells of the mould as a guide). Brush the edges of each ravioli piece with egg yolks or water using a pastry brush or your finger.
5. Bring a large pan of salted water to the boil. Carefully lower the ravioli into the water, in batches, and cook for 3-4 minutes; they are cooked when they float to the surface of the water.
6. Serve the ravioli in serving bowls and cover with the warm sauce and sprinkle with parmesan.

Serves 6

Chicken, Leek & Mozzarella with Creamy leek Sauce

FILLING -

- 15g butter
- salt and freshly ground black pepper
- 1 small chicken breast, finely chopped
- 15g mozzarella, finely chopped
- 1 tbsp chopped basil
- 1 clove garlic, finely chopped
- 1 sheet of fresh lasagne, cut into six 7cm/3-inch strips, blanched
- 2 free-range egg yolks, beaten
- olive oil, to drizzle

SAUCE -

- ☒ leek, finely chopped
- 50ml white wine
- 50ml double cream
- salt and freshly ground black pepper
- 1 tbsp chopped parsley

METHOD -

1. Preheat the oven to 200C/400F/Gas 6.
2. In a small frying pan, melt the butter. Season the chicken, then add to the pan to brown on all sides.
3. In a mixing bowl, mix together the mozzarella, basil and garlic. Fill the Ravioli pieces with the chicken and mozzarella mixture. Use the egg yolks to brush around the edges before placing the Ravioli dough pieces on top and firmly sealing.
4. Place on a baking tray, drizzle with olive oil and bake in the oven for 10-12 minutes, or until cooked through.
5. Meanwhile for the sauce, simmer the leek in a pan with the wine for 5 minutes before stirring in the cream and season with salt and freshly ground black pepper.
6. Finish with the parsley, then spoon over the ravioli to serve.

Serves 1.

TIP: If your pasta is too wet and is becoming too sticky, add more flour to the mixture. If your pasta is too dry and is starting to crumble, add a small amount of water to the mixture to moisten and reform.

CLEANING & MAINTENANCE

CAUTION: DO NOT wash any part of your VonShef Pasta Maker in water or place in a dishwasher. **DO NOT** wipe down with wet cloths or sponges as these can damage the rollers.

- Dried on pasta is best removed using a dry wire cleaning brush (not supplied). **DO NOT** insert blades or sharp parts into the Pasta Maker for any reason.
- Flour and residue can be removed by running a basic dough through the appliance until removed. **DO NOT** wipe down with wet cloths or sponges as these can damage the rollers.
- Wipe down with a dry cloth or kitchen towel. Clean the top and underside of the appliance and rollers as thoroughly as possible.

TIP: It is recommended to occasionally add several drops of olive oil to the ends of the rollers to ease use.

CUSTOMER SERVICES

If you are having difficulty using this product and require support, please contact support@vonhaus.com

DISPOSAL INFORMATION

Please recycle where facilities exist. Check with your local authority for recycling advice.

WARRANTY

To register your product and find out if you qualify for a free extended warranty, go to:

www.vonhaus.com/warranty

Please retain a proof of purchase receipt or statement as proof of the purchase date.

The warranty only applies if the product is used solely in the manner indicated in this manual and all instructions have been followed accurately. Any abuse of the product or the manner in which it is used will invalidate the warranty.

Returned goods will not be accepted unless re-packaged in its original packaging and accompanied by a relevant and completed returns form. This does not affect your statutory rights.

No rights are given under this warranty to a person acquiring this appliance second-hand or for commercial or communal use.

COPYRIGHT

All material in this instruction manual are copyrighted by DOMU Brands Ltd.

Any unauthorised use may violate worldwide copyright, trademark, and other laws.

Thank you for purchasing the Manual Pasta Maker.

VonShef is a registered trademark of DOMU Brands Ltd.

Made in China for DOMU Brands Ltd.

Unit 30, Stakehill Industrial Estate, Middleton, Manchester, M24 2RW