

vonhaus

WET / DRY VACUUM

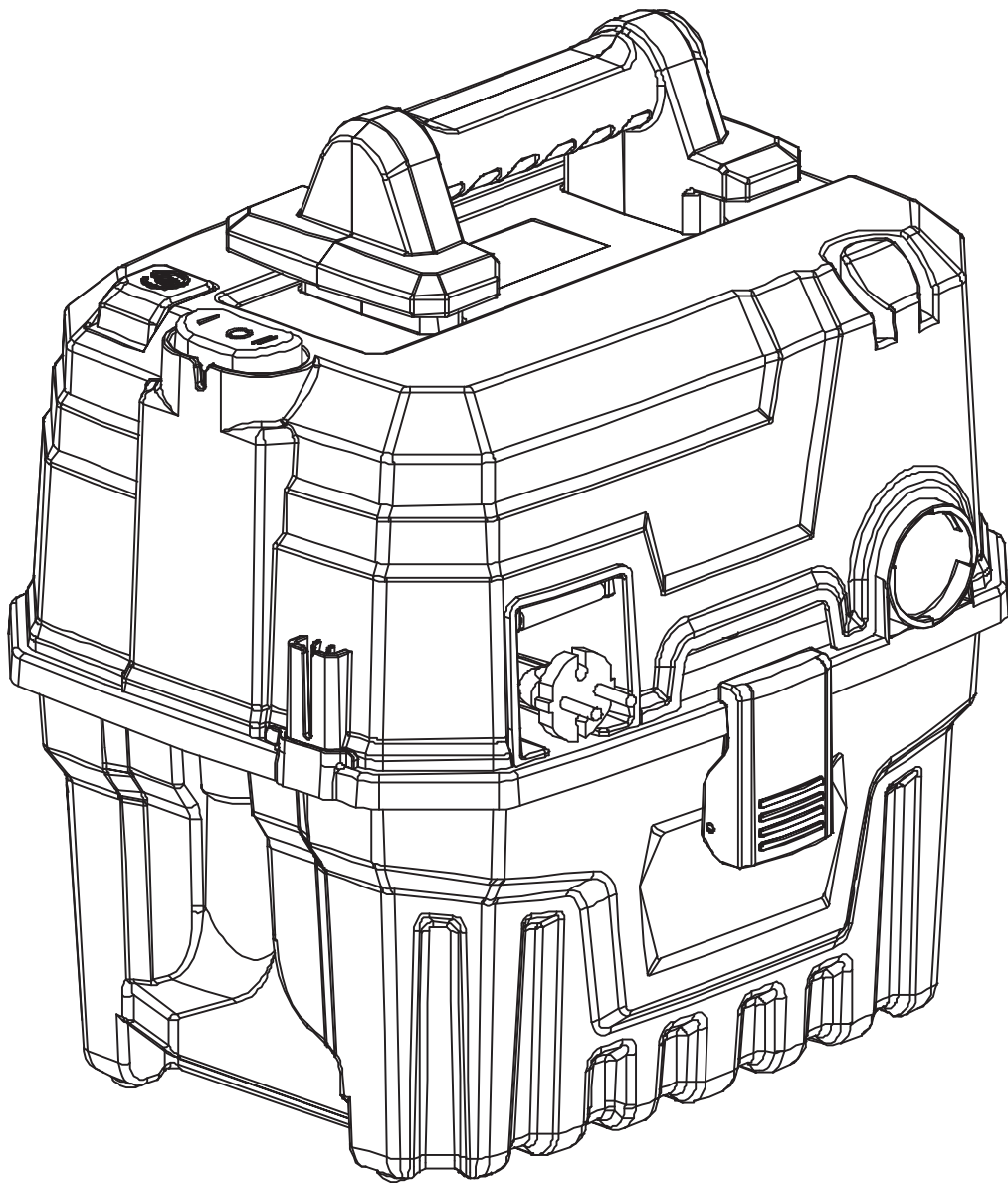

Setup Instructions

Product No. 3500391

Let's get started!

Visit our product hub for useful tips and tricks on getting the most out of your new product.

SCAN ME



Need further help?
support@vonhaus.com

See our full range at
www.vonhaus.com

Components

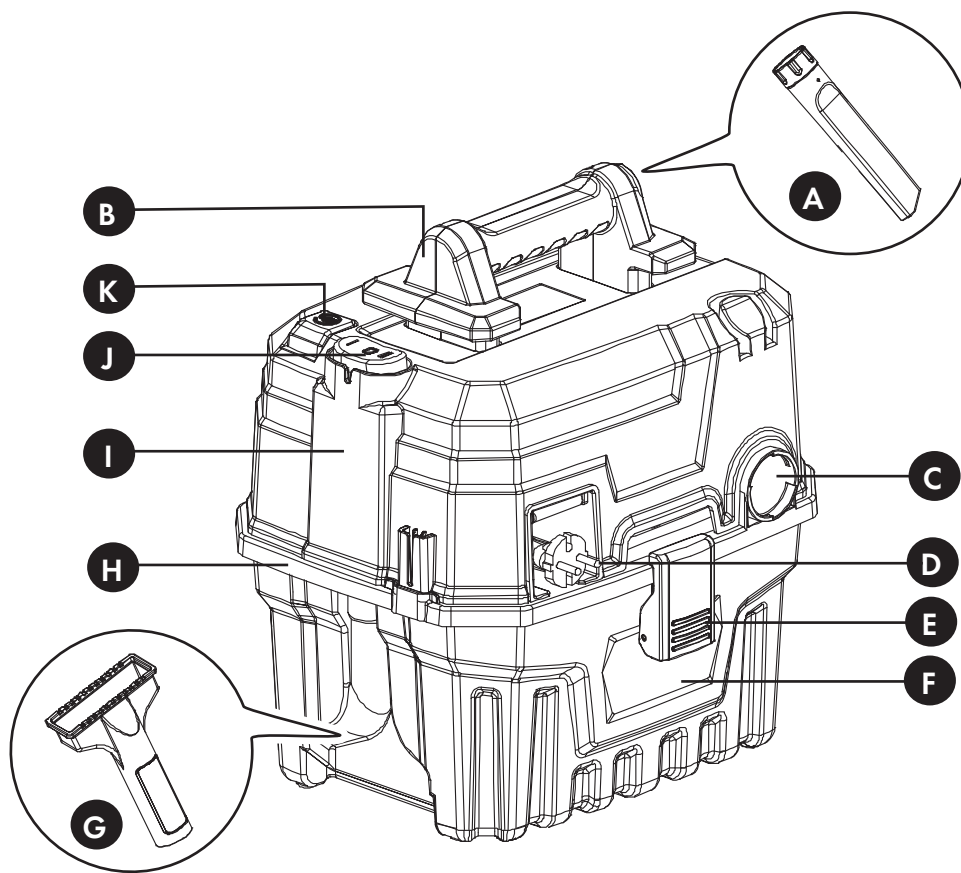

Accessories

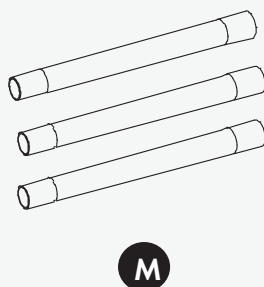
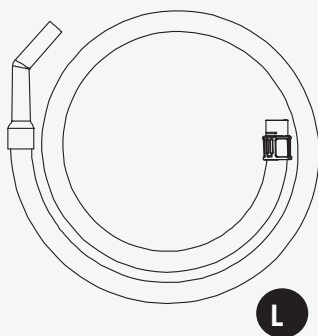

- A. Crevice Nozzle
- B. Handle
- C. Air Outlet
- D. Power Cord
- E. Barrel Lock
- F. Barrel

- G. Vacuuming Nozzle
- H. Barrel Cover
- I. Top Cover
- J. ON/OFF Switch
- K. Auto Coil Button
- L. Hose Assembly

- M. Tube
- N. Cartridge Filter
- O. Water-Absorbing Sponge

Installation

Read the Instructions on Page 15

1

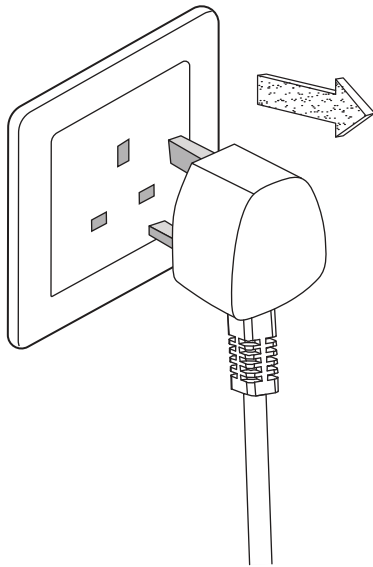

2

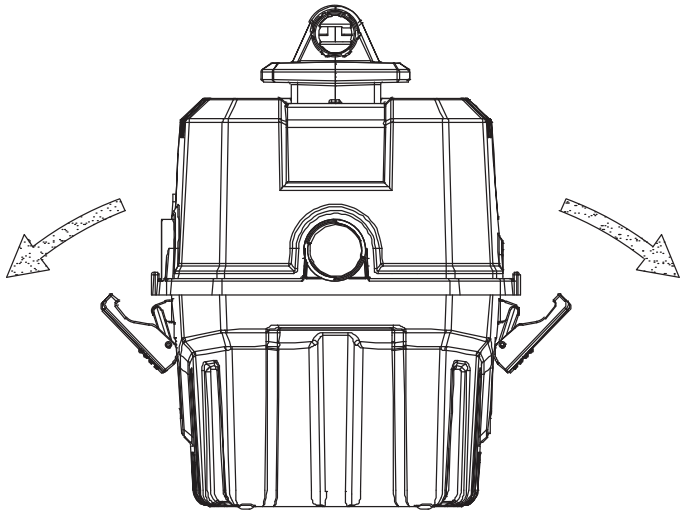

3

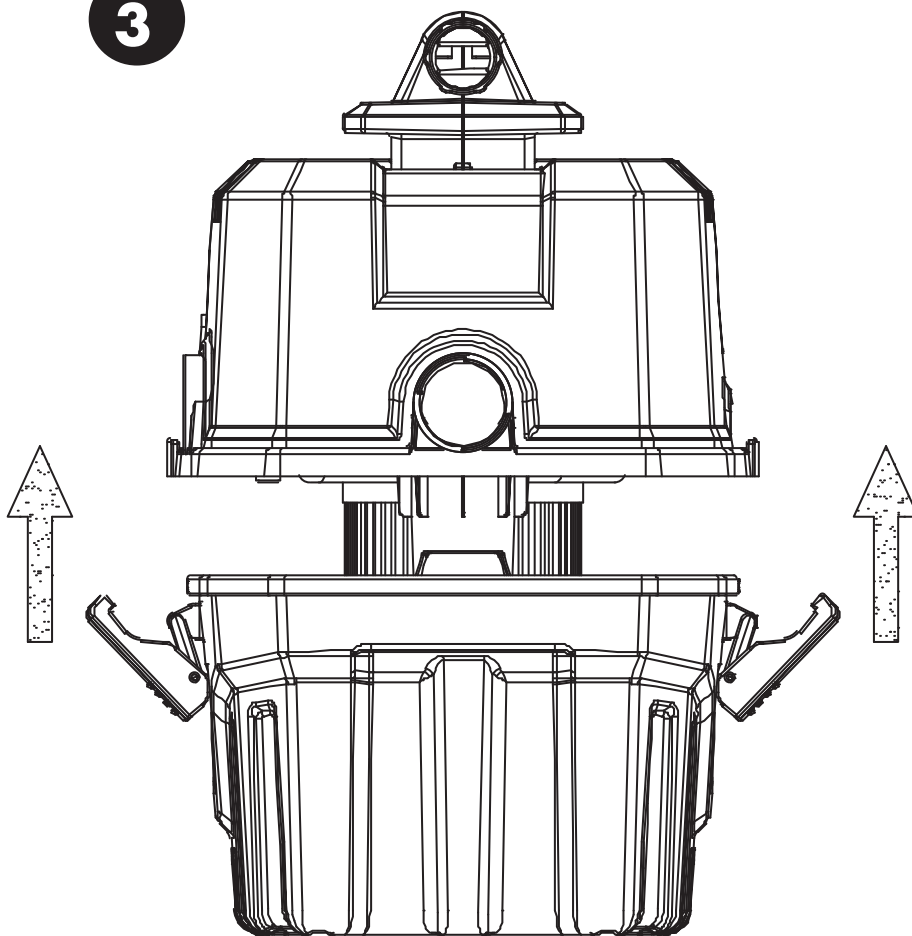

4

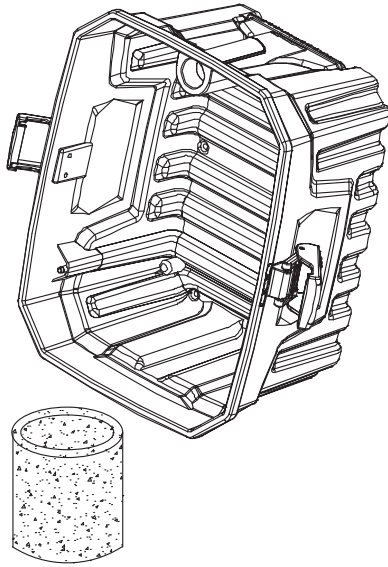

5

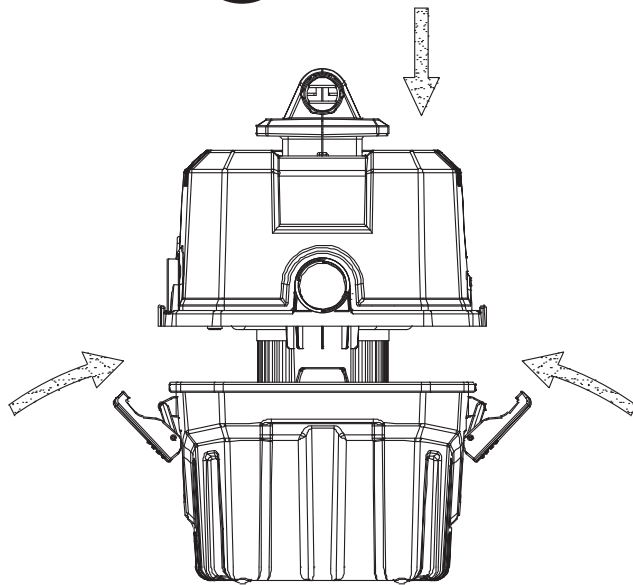

6

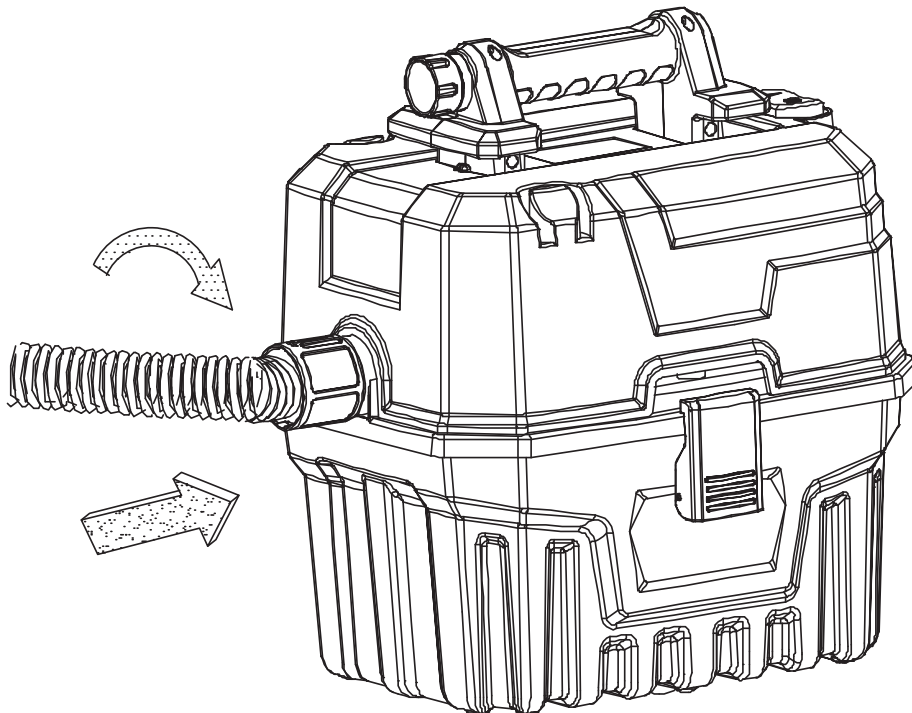

Installation

Read the Instructions on Page 15

7

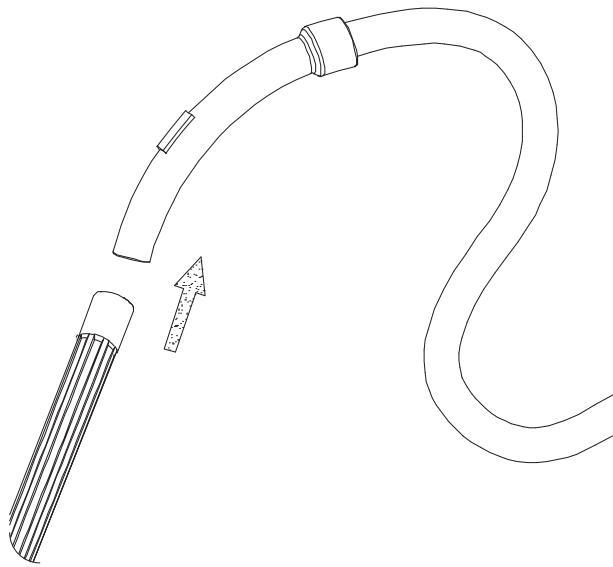

8

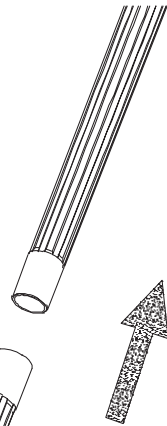

9

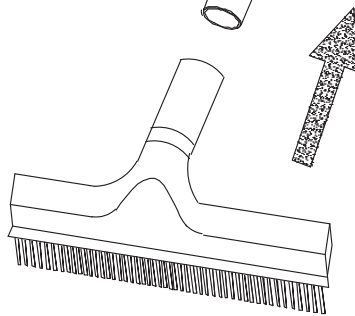

10

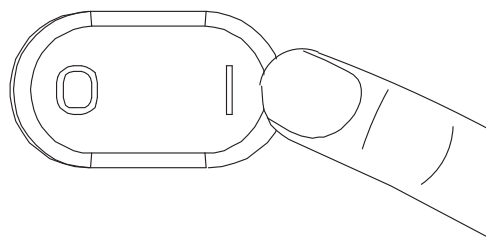

1

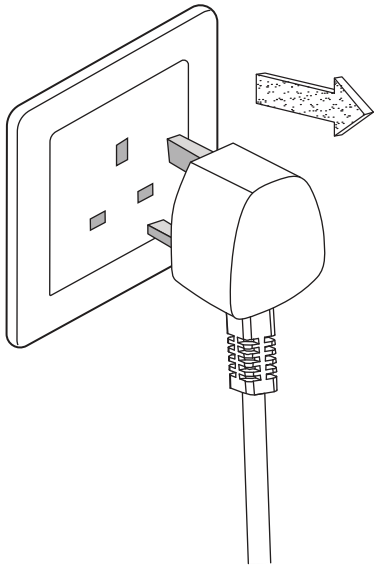

2

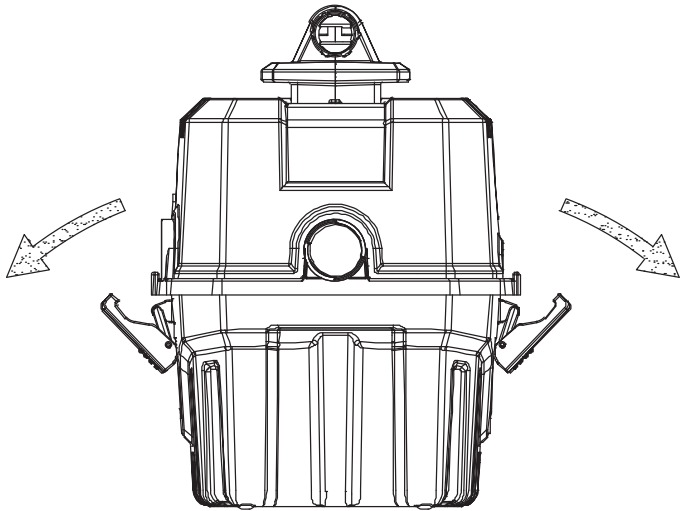

3

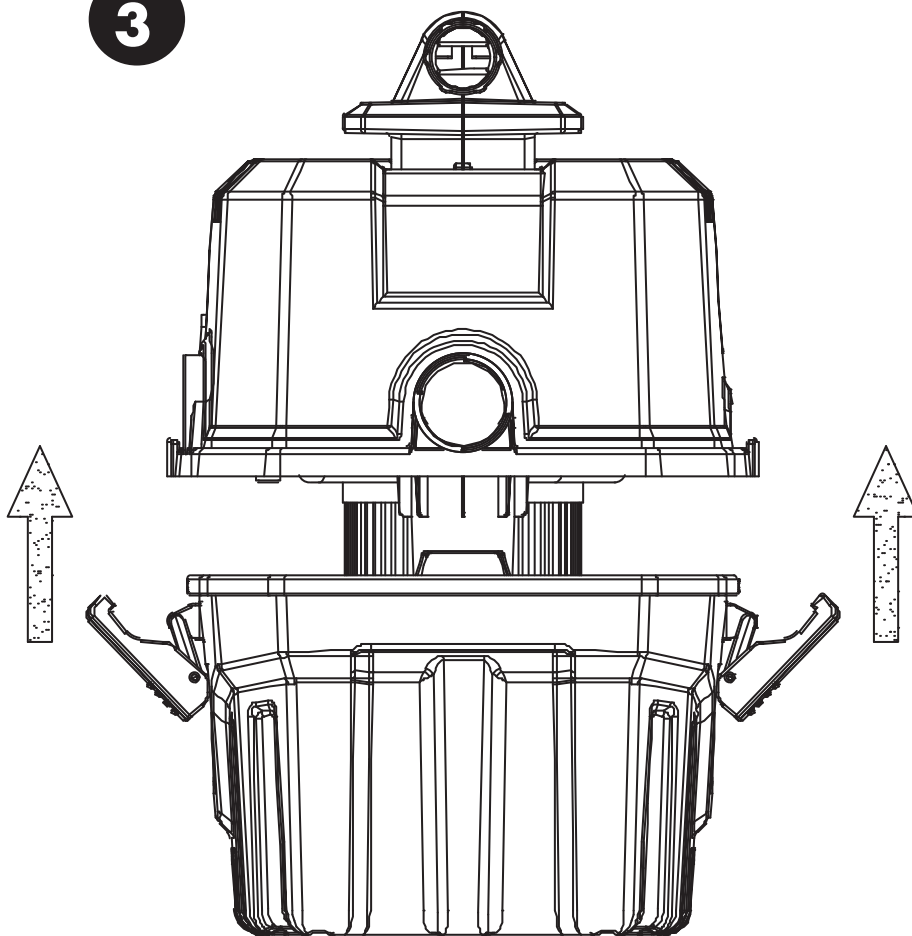

4

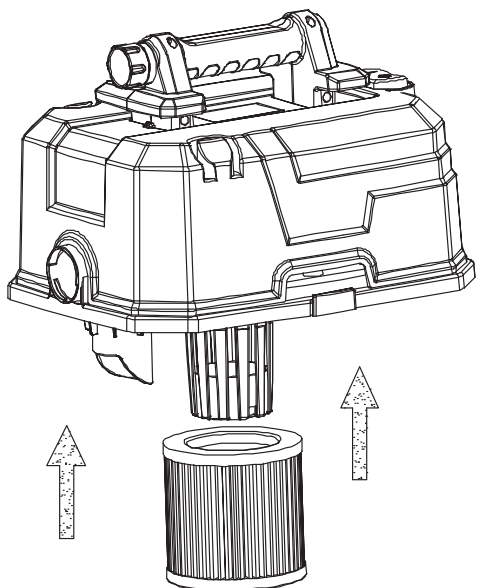

5

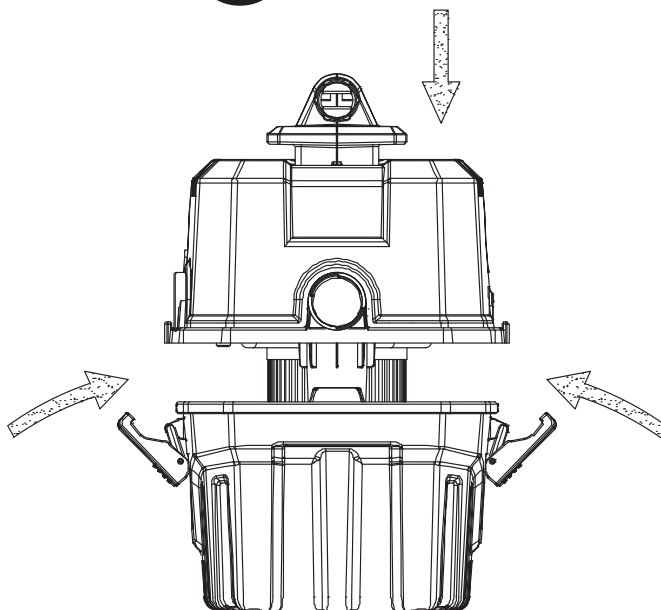

6

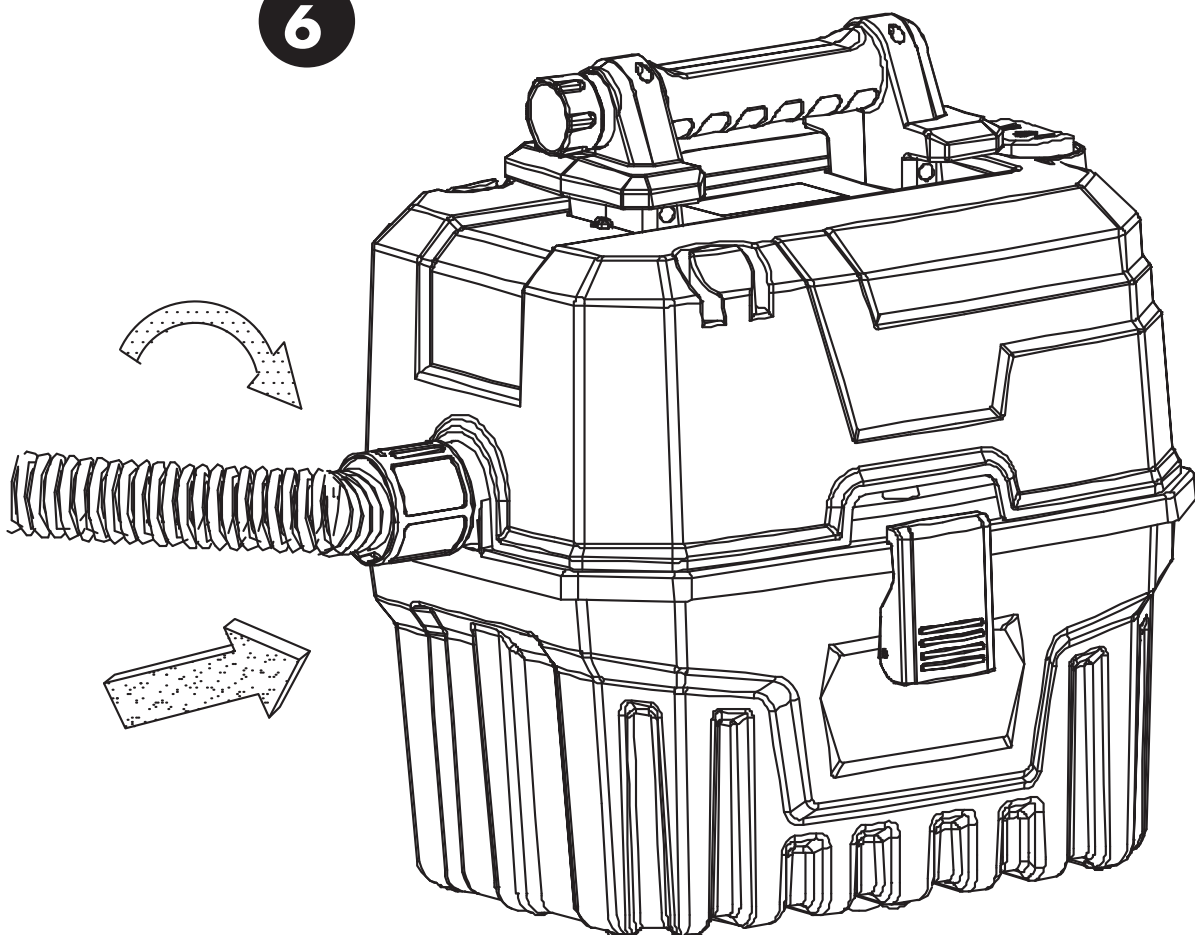

Dust Vacuum

Read the Instructions on Page 15

7

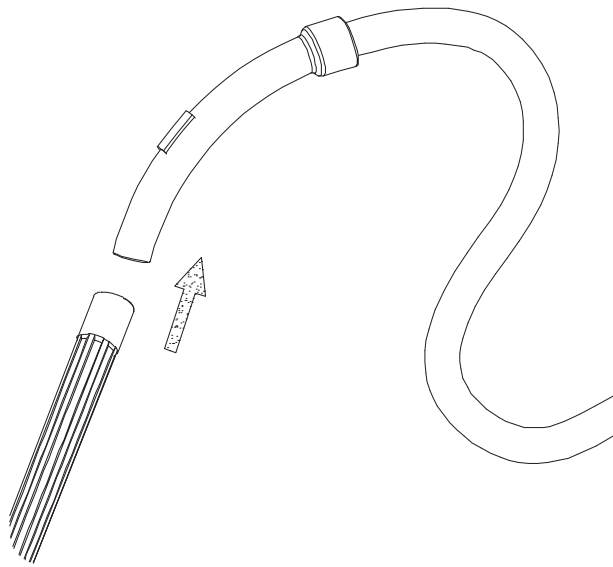

8

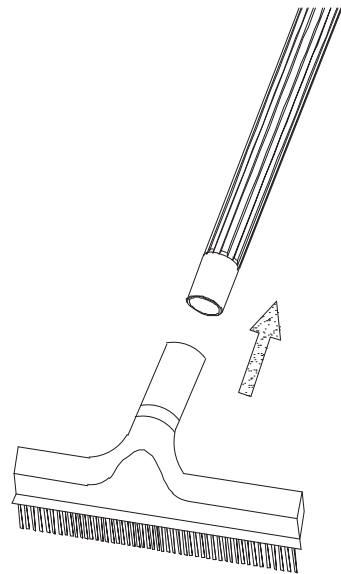

9

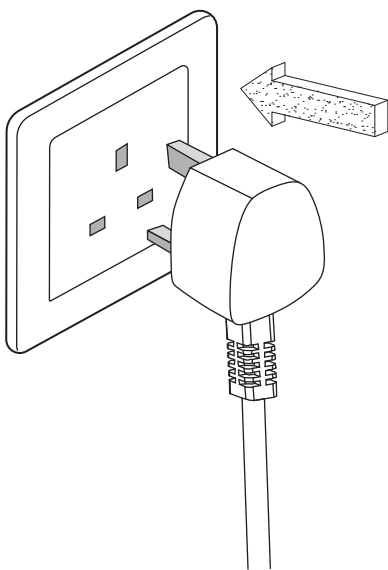

10

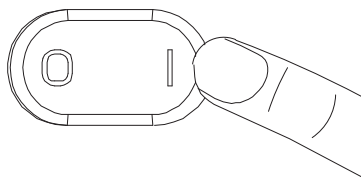

11

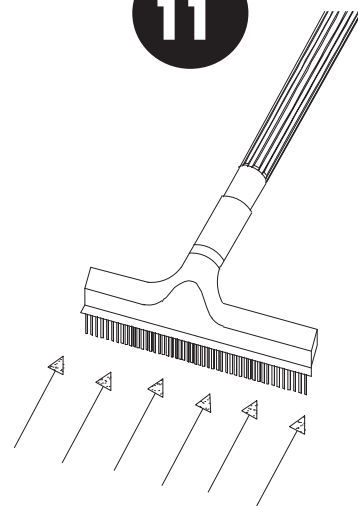

1

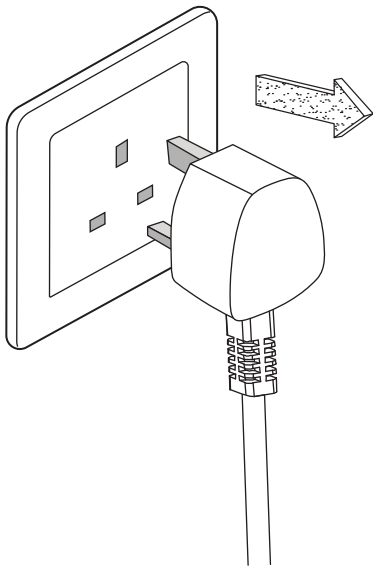

2

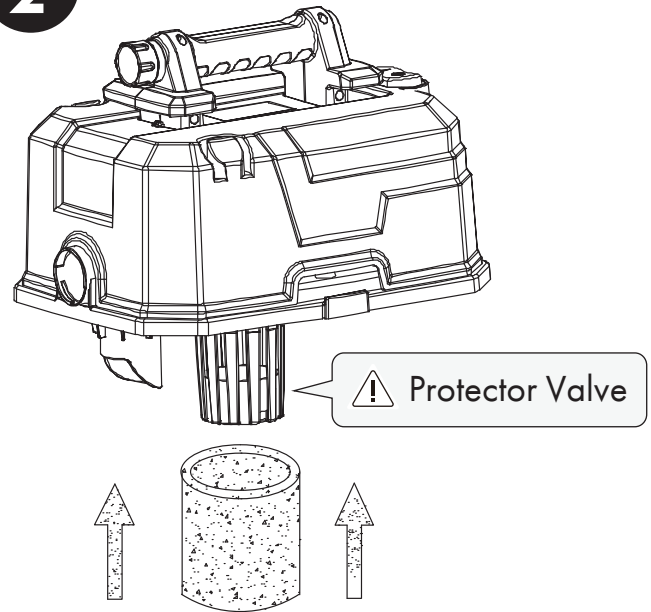

⚠ Protector Valve Notice

A protector valve is located at the marked position above. It protects the motor by rising when the tank is full.

If the valve rises, the vacuum will make unusual noise and lose suction. **Immediately turn off the unit to prevent motor damage.**

3

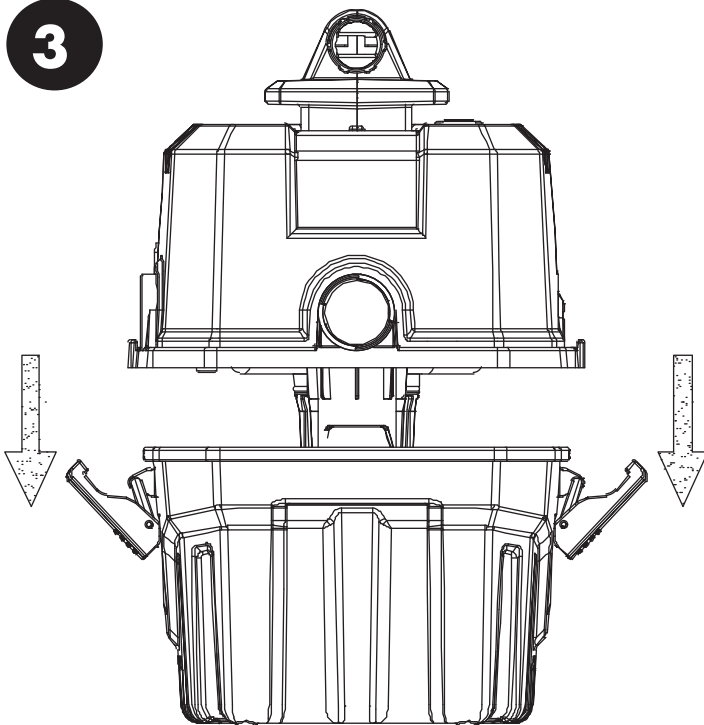

4

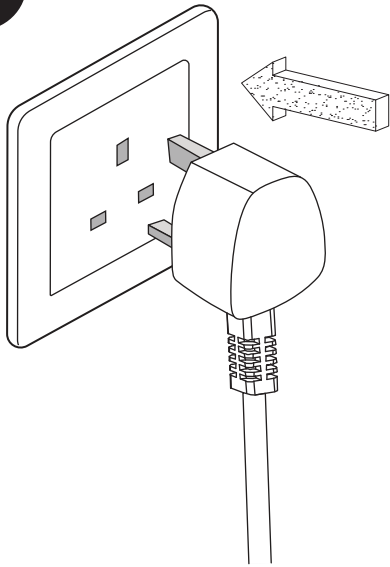

5

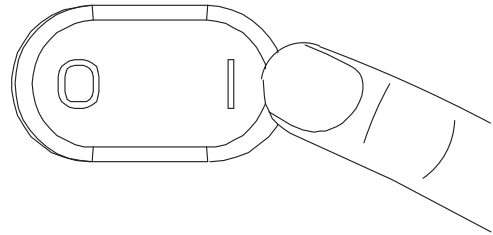

6

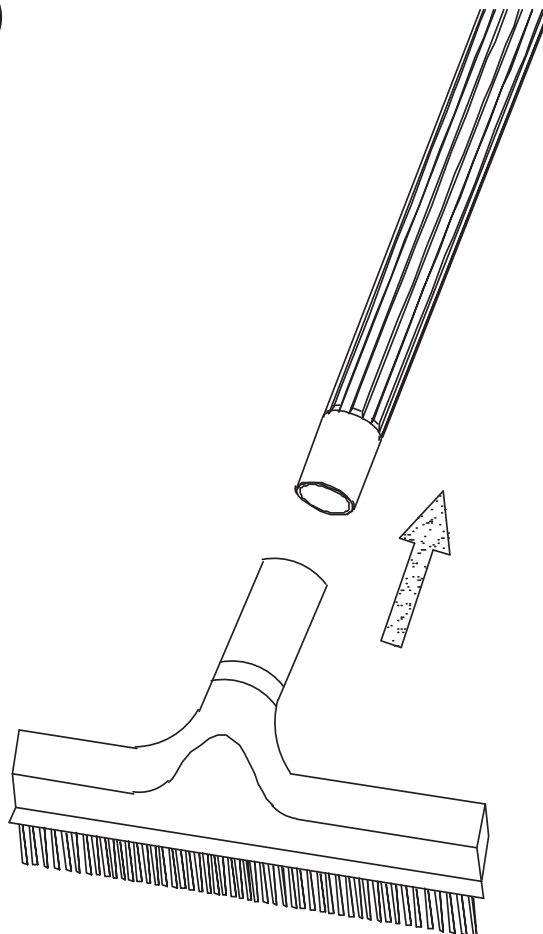

7

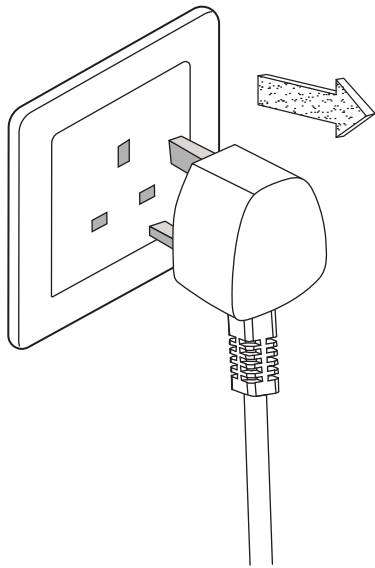

8

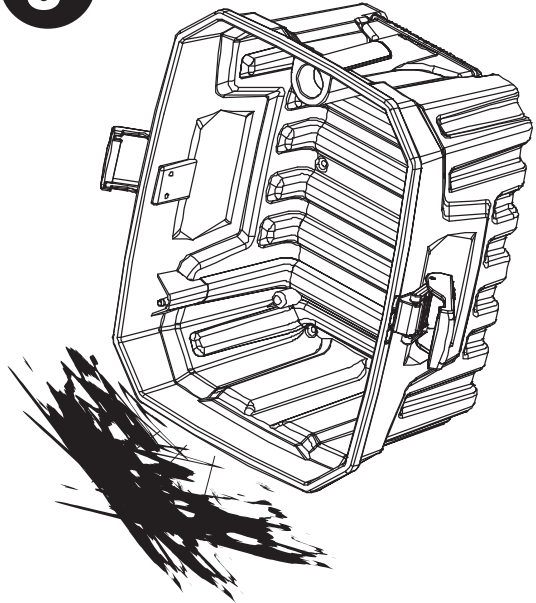

9

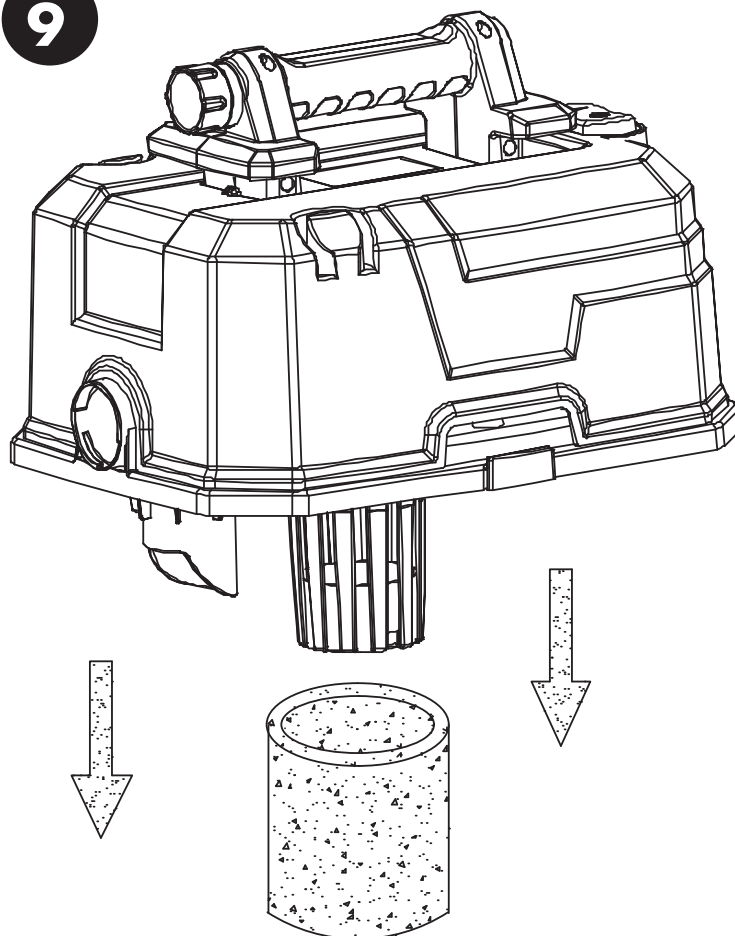

10

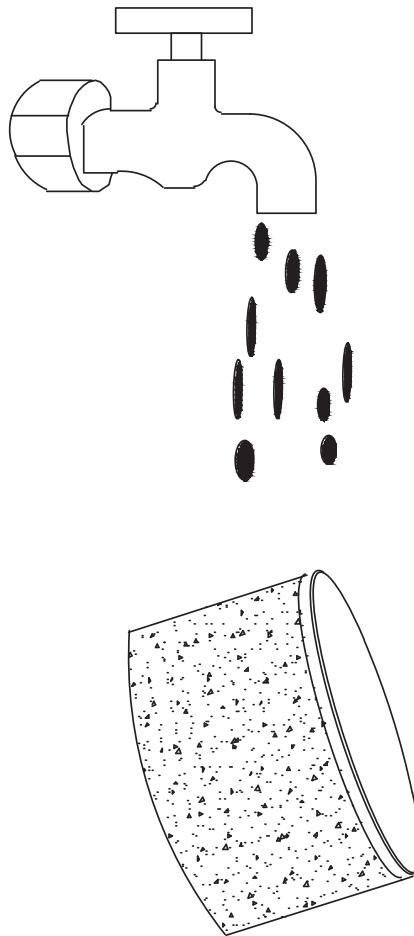

Filter Cleaning

1

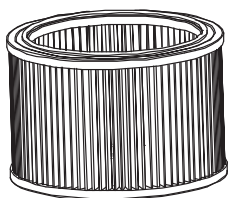
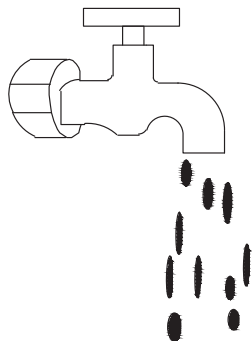

2

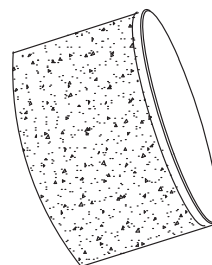
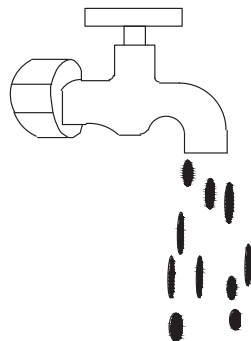

3

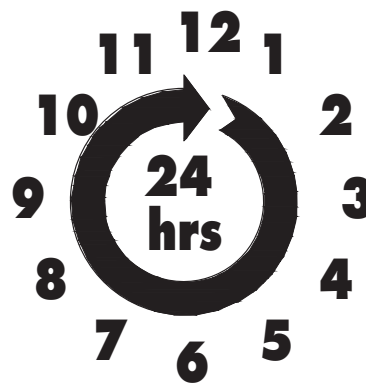
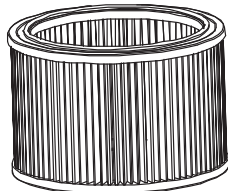
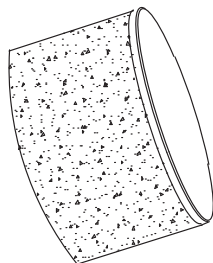
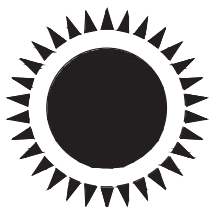

1. If vacuuming very fine dust, the filter may require more frequent cleaning.
2. Wash the filter sponge with cold or warm water, avoiding detergent.
3. Allow the cleaned parts to dry complete-

ly in a well-ventilated area for at least 24 hours. Do not place the filter in a dishwasher, washing machine, tumble dryer, oven, microwave, or near an open flame.

Information

Installation

1. Ensure the vacuum is unplugged.
2. Disconnect the power cord from the socket and loosen the clips.
3. Lift the nose assembly from the dust pan and remove all accessories from the dust container.
4. Place the nose assembly on the dust barrel with the filter assembly and lock it in place with the clips on both sides.
5. Align the hose assembly port with the suction port, insert it to the right, and tighten it.
6. Optional: Install the tube and hose assemblies by inserting the larger end of the tube.
7. Optional: Install the brush and tube assembly by plugging one end of the brush into place.

Dust Vacuum Operation

1. Disconnect the power cord from the socket and loosen the clips.
2. Lift the head assembly from the dust tank and install the HEPA filter by pressing it firmly onto the bottom cap basket.
3. Place the nose assembly on the dust bucket and secure it with the buckles on both sides.
4. Align the hose assembly port with the suction port, rotate it to the right, and insert it. Optionally, install the tube and hose assemblies or the brush and tube assembly.
5. Plug in the power cord, press the switch button, and start the vacuum.

Wet Vacuum Operation

1. Ensure the power cord is disconnected from the socket. Cover the bottom cap basket with the water-absorbing sponge.
2. Place the head assembly on the dust barrel and secure it with the clips on both sides.
3. Install the required suction accessories on

the hose assembly.

4. Connect the power cord and press the switch to start. When the water reaches maximum capacity, the safety valve will activate, causing the suction port to lose suction. Turn off the power and disconnect the power cord.
5. Pour out the water. To ensure optimal water absorption, remove the air filter sponge, wring it dry by hand after drainage, and wash it with clean water. Wring it dry again after washing, and reuse it.

Blower Operation

1. Disconnect the power cord from the socket.
2. Unscrew the hose assembly from the suction port by turning it left.
3. Insert and tighten the main cannula of the hose assembly into the air outlet at the back of the head by turning it right.
4. Plug in the power cord (see Fig 4) and press the switch button to start.
5. Hold the hose assembly, aiming the outlet port at the leaves or debris.

Specifications

Input Voltage: 220-240V~, 50/60Hz

IP Rating: IPX4

Details: Class II

Information

Important Safety Notice

This product is not suitable for use by children or by individuals with physical, sensory, or mental impairments that may limit their ability to operate the equipment safely, unless they have been given supervision or instruction concerning the safe use of the product by a person responsible for their safety.

Improper use may result in serious injury. Always ensure the operator is capable of understanding and following all safety instructions provided in this manual.

Health & Safety

Carefully read and understand all instructions before use.

Follow basic precautions when using electrical appliances.

Do not leave the appliance unattended during operation.

Ensure the electrical voltage is correct before use.

Do not direct the air outlet towards people or animals.

The manufacturer is not liable for damages from improper use.

Avoid using on flammable or toxic liquids, such as petrol, oil, acids, or other volatile substances.

Only qualified professionals should repair electrical equipment; improper repairs can pose significant risks.

Store the appliance away from high temperatures, like hot stoves or radiators.

Do not use cleaning agents or detergents containing solvents.

This device is not suitable for children or inexperienced users unless supervised or instructed. Ensure children do not play with the appliance. Turn off and unplug the appliance before cleaning or servicing.

Maintenance

- When the dust bucket is full, turn off the switch and unplug the power cord.
- Release the buckle and remove the nose assembly from the dust container.
- Empty the dust bucket.
- Periodically check the filter to maintain optimal performance; it may need more frequent cleaning if vacuuming fine dust.
- Wash the filter sponge with cold or warm water, avoiding detergent.
- Allow cleaned parts to dry completely in a well-ventilated area for at least 24 hours.
- Do not place the filter in a dishwasher, washing machine, tumble dryer, oven, microwave, or near an open flame.

Troubleshooting

Why is the vacuum not turning on?

Ensure the power cord is plugged in and that the outlet is functioning properly.

Why is the vacuum losing suction power?

Check if the filter is clogged or if the dust container is full.

Why is the vacuum making unusual noises?

Inspect the hose and attachments for any blockages.

Why is the vacuum not picking up water?

Ensure the vacuum is set to wet mode and that the float valve is working correctly.

Why is the vacuum emitting a bad odor?

Clean or replace the filter and empty the dust container.

Legal

DISPOSAL INFORMATION

Please recycle where facilities exist. Check with your local authority for recycling advice.

CUSTOMER SERVICE

If you are having difficulty using this product and require support, please contact support@vonhaus.com

WARRANTY

To register your product and find out if you qualify for a free extended warranty please go to www.vonhaus.com/warranty.

Please retain a proof of purchase receipt or statement as proof of the purchase date.

The warranty only applies if the product is used solely in the manner indicated in the warnings page of this manual, and all other instructions have been followed accurately.

Any abuse of the product or the manner in which it is used will invalidate the warranty.

RETURNS

Returned goods will not be accepted unless re-packaged in its original packaging and accompanied by a relevant and completed returns form. This does not affect your statutory rights.

No rights are given under this warranty to a person acquiring the appliance second-hand or for commercial or communal use.

COPYRIGHT

All material in this instruction manual are copyrighted by DOMU Brands.

Any unauthorised use may violate worldwide copyright, trademark, and other laws.

Thank You

Thank you for purchasing your product/appliance. Should you require assistance with your purchase, please contact us at support@vonhaus.com

VonHaus is a registered trademark of DOMU Brands Ltd. Made in China for DOMU Brands. Industrial Estate, Middleton, Manchester M24 2RW.

Authorised Representative

Authorised Representative Service
77 Camden Street Lower
Dublin, D02 XE80, Ireland



Product No. 3500391