

DIGITAL SAFE SMALL

Product Instructions

Product No. 3515437

vonhaus

Let's get started!

Visit our product hub for useful tips and tricks on getting the most out of your new product.

SCAN ME



Product Diagram

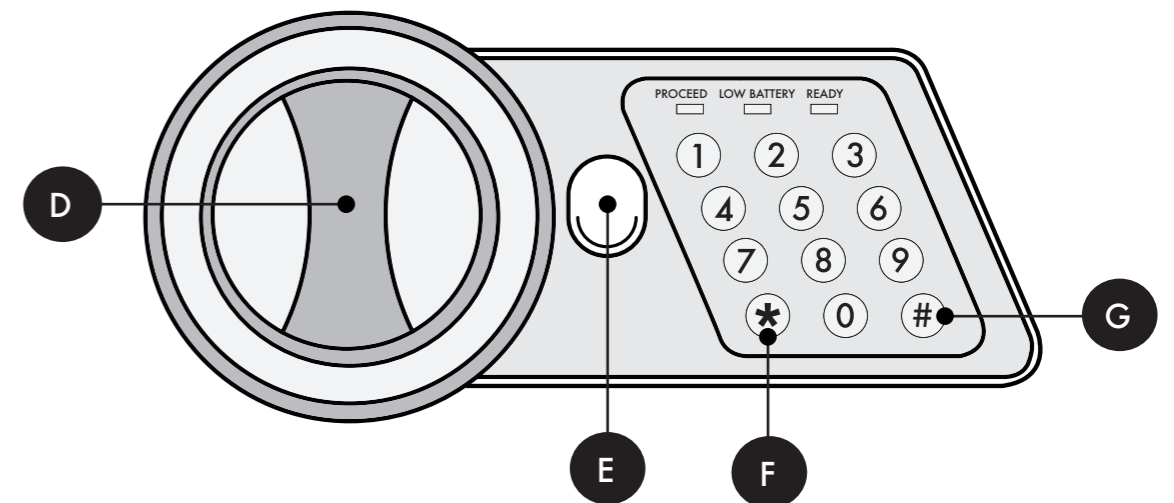
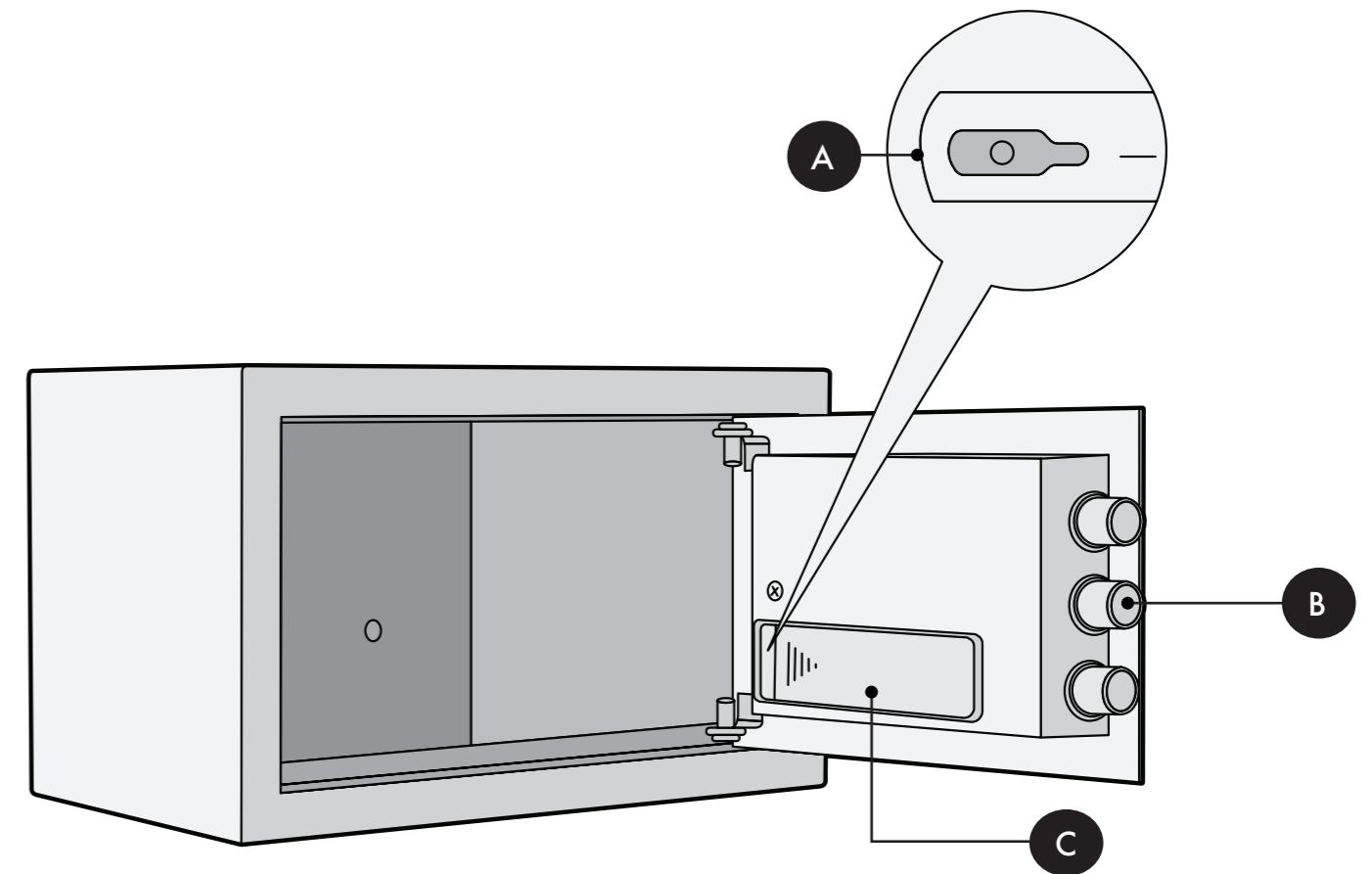

Need further help?
support@vonhaus.com

See our full range at
www.vonhaus.com

- A. Reset Button
- B. Bolts
- C. Battery Compartment
- D. Knob

- E. Emergency Lock Cover
- F. Delete Button
- G. Confirmation Button

Opening for the First Time

IMPORTANT! You can also use this method to open the safe if you forget your code or the electronics fail.

1. Slide the emergency lock cover up to reveal the key hole.
2. Insert the emergency key and turn it anticlockwise.
3. Then turn the knob clockwise to open the door.

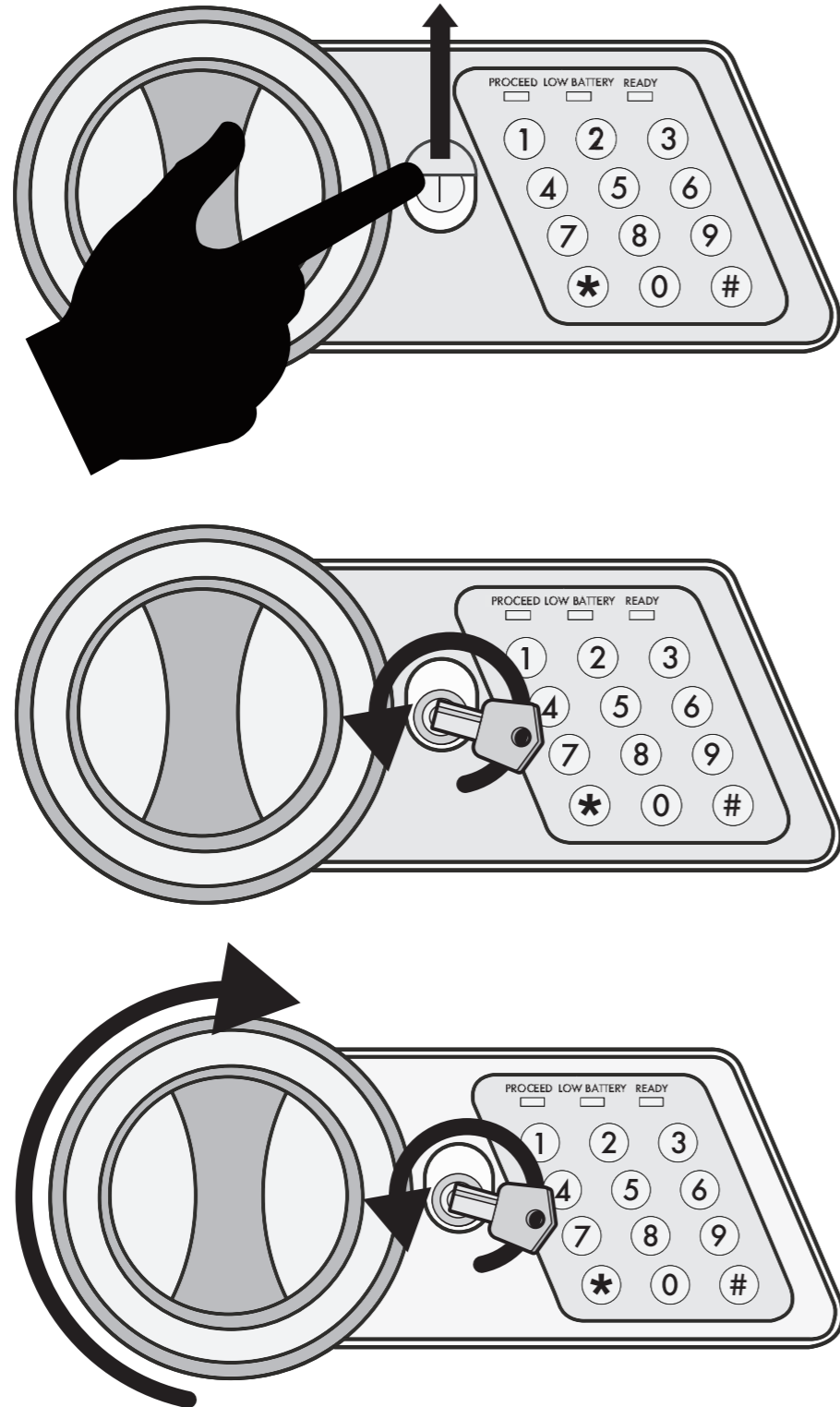

Information

To Open

1. Enter your code (each number beeps and flashes yellow)
2. Press “#” (green light turns on)
3. Turn knob right and pull within 5 seconds

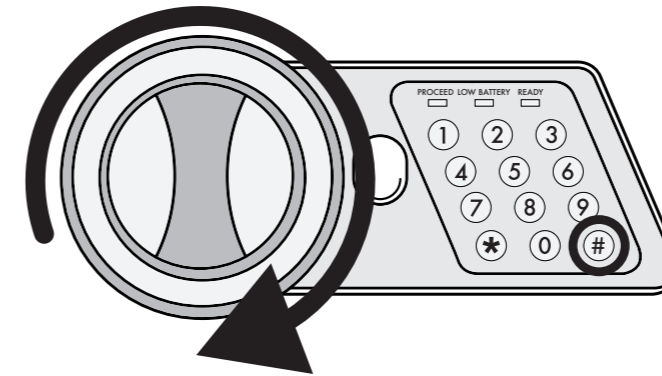
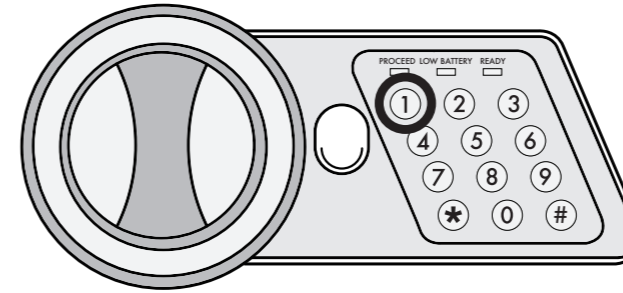

To Close

1. Close the door
2. Turn knob left to lock

Automatic Lock

- 3 continuously wrong entries will activate warning beep for 20 seconds.
- Another 3 continuously wrong entries will activate the warning beep for 5 minutes.

CAUTION: The keypad would be disabled during the alarm period. You can only stop the alarm by opening the safe with emergency key and power-cut by removing the battery.

Setting the User Code

1. With the door open, press the reset button once, start setting code when the yellow light goes on.
2. Input new user code (3 to 8 digits) and press “#” button to confirm with 2 buzzer beeps, which indicates the acceptance and storage of the new code.
3. If the yellow light flashes with 3 buzzer beeps, which means the code changing is not effective and you need to try again.

Default code: New safes come set to “159” - change this immediately!

Mute Mode

Input “00” and “*” to activate mute mode; input “66” and “*” to cancel mute mode.

Inserting the Batteries

1. Open the door and remove the battery compartment cover.
2. Insert 4 X AA batteries into the battery compartment.
3. Under normal use of the safe, the red and green lights are on when safe unlock, it means the voltage is low and you should change new batteries.

CAUTION: Replace 4 fresh batteries by lining them up in a manner as indicated by the “+” and “-” signs. When outage for longer than 30 minutes, you should reset the user code!

Mounting Method



CAUTION: Use expansion bolts when there is a concrete wall surface. Use clamping screws when there is a wooden wall surface.

Instructions

1. Fix the safe in the place where it is not easy to move.
2. Drill holes for expansion bolts (or clamping screws) in the correct position.
3. Turn the expansion bolts anticlockwise to separate them.
4. Use the expansion bolts (or clamping screws) to secure the case to the wall.
5. Make sure the case is mounted in place as required, then tighten all screws.

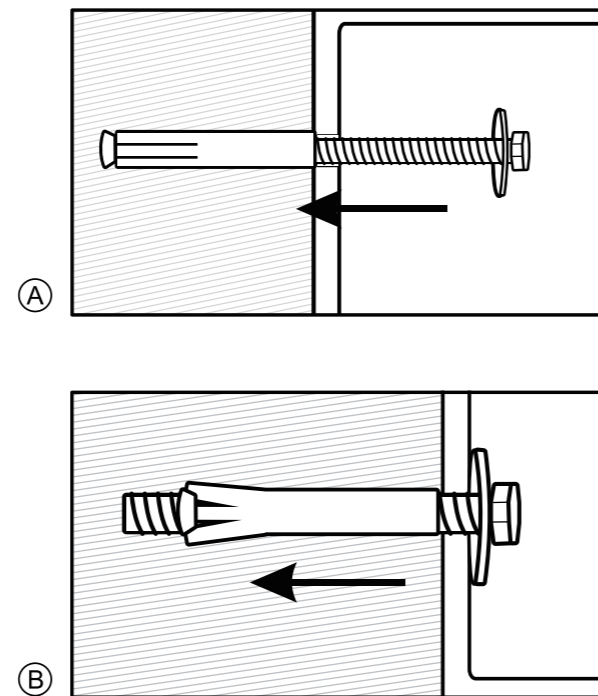
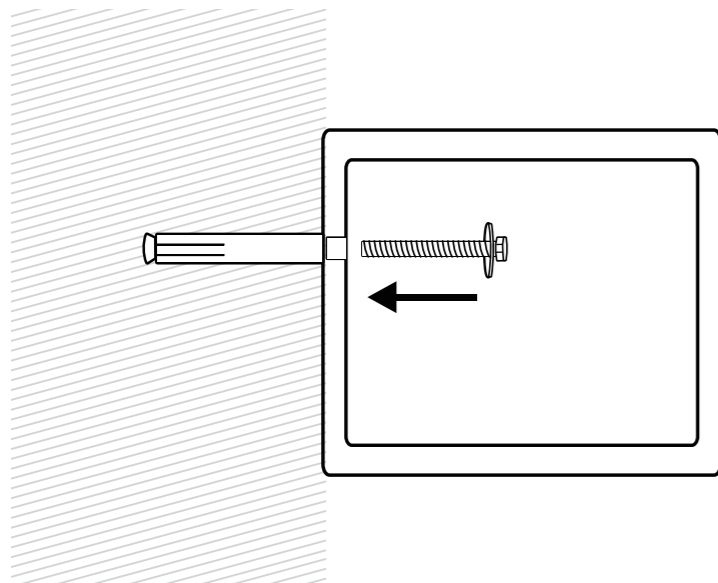

Information

Important Safety Notice

This product is not suitable for use by children or by individuals with physical, sensory, or mental impairments that may limit their ability to operate the equipment safely, unless they have been given supervision or instruction concerning the safe use of the product by a person responsible for their safety.

Improper use may result in serious injury. Always ensure the operator is capable of understanding and following all safety instructions provided in this manual.

Customer Service

If you are having difficulty using this product and require support, please contact support@vonhaus.com

Warranty

To register your product and find out if you qualify for a free extended warranty please go to www.vonhaus.com/warranty

Please retain a proof of purchase receipt or statement as proof of the purchase date.

The warranty only applies if the product is used solely in the manner indicated in the warnings page of this manual, and all other instructions have been followed accurately.

Any abuse of the product or the manner in which it is used will invalidate the warranty.

Returns

Returned goods will not be accepted unless re-packaged in its original packaging and accompanied by a relevant and completed returns form. This does not affect your statutory rights.

No rights are given under this warranty to a person acquiring the appliance second-hand or for commercial or communal use.

Copyright

All material in this instruction manual are copyrighted by DOMU Brands.

Any unauthorised use may violate worldwide copyright, trademark, and other laws.

Thank You

Thank you for purchasing your product/appliance.

Should you require assistance with your purchase, please contact us at support@vonhaus.com

VonHaus is a registered trademark of DOMU Brands Ltd.

Made in China for DOMU Brands Ltd.
Unit 30, Stakehill Industrial Estate
Middleton, Manchester, M24 2RW

EU Authorised Representative

Authorised Representative Service
77 Camden Street Lower
Dublin, D02 XE80
Ireland

Let's get started!

Visit our product hub for useful tips and tricks on getting the most out of your new product.

SCAN ME

